

SPR 410 SPEED INCREASER

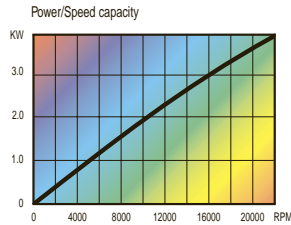

- Auto tool change capability
- Alternative drive tapers available
- Maintenance free sealed unit

* Pin centre distance to suit application

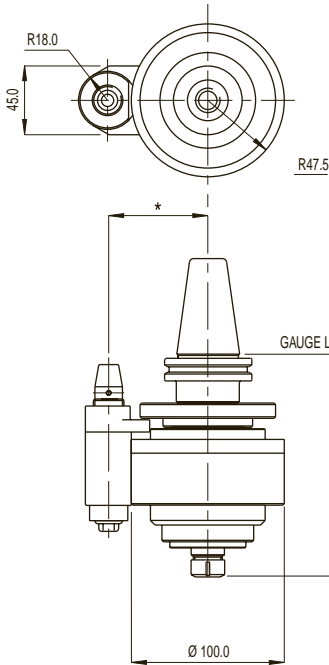

Max. speed - 20% running	22,000 rpm
Max. speed - constant	20,000 rpm
Max. tool shank dia.	10 mm / 3/8"
Ratio	4:1
Rotation	Same
Drive taper	40 BT-CT-DIN-HSK
Tool holding	Collet chuck ER16
Max. weight without tooling	5.2 kg / 12 lbs

SPR 410 QC 30 SPEED INCREASER

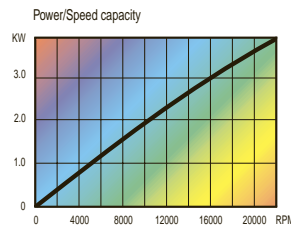
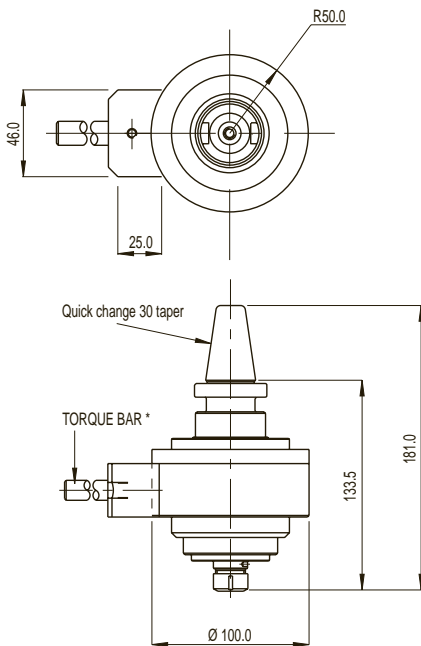

- Alternative drive tapers available
- Maintenance free sealed unit

* Torque bar for manual tool change to prevent rotation



Max. speed - 20% running	22,000 rpm
Max. speed - constant	20,000 rpm
Max. tool shank dia.	10 mm / 3/8"
Ratio	4:1
Rotation	Same
Tool holding	Collet chuck ER16
Max. weight without tooling	5.2 kg / 12 lbs