

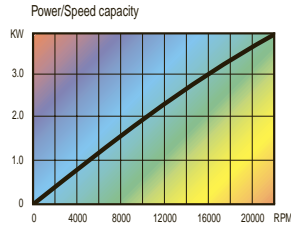

SPR 410 R8 SPEED INCREASER R8 SHANK



Max. speed - 20% running	22,000 rpm
Max. speed - constant	20,000 rpm
Max. tool shank dia.	10 mm / 3/8"
Ratio	4:1
Rotation	Same
Tool holding	Collet chuck ER16
Max. weight without tooling	5.2 kg / 12 lbs

The 410-R8 Speed Increaser allows users of turret mills to increase spindle speed to the levels required by modern tooling at an affordable price.

- Alternative drive tapers available
- Maintenance free sealed unit

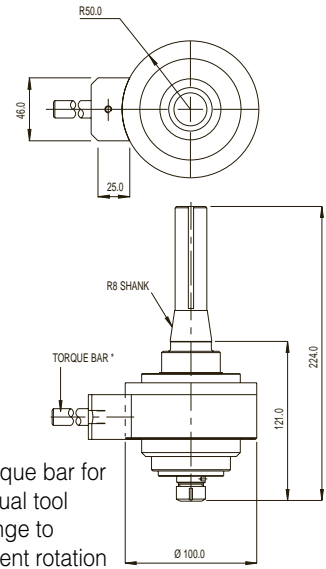

* Torque bar for manual tool change to prevent rotation